



Q MICROWAVE, INC.

1 GHz Bandwidth Wideband RF Downconverter 0.5 to 18 GHz Frequency Range

Typical Applications

-) Frequency Conversion
-) Electronic Warfare Systems
-) Radar Systems



Features

-) **RF Frequency Range**
 -) 0.5 to 18 GHz
-) **IF Frequency Range**
 -) 1800 to 2800 MHz

-) **1 GHz Instantaneous Bandwidth**
-) External LO's Required
-) Frequency Agile across Entire Band
-) Voltage +/- 6, or +12, VDC
-) Small Size 6.8 x 2.75 x 0.55 inch
-) Rugged Hermetic Package
-) DC Test Cables Available Upon Request

General Description

Q Microwave's PN 102256 is a frequency-agile RF Downconverter capable of converting frequencies centered between 0.5 and 18 GHz, with 1 GHz of instantaneous bandwidth.

The 1000 MHz IF frequency range is centered at 2300 MHz (1800 to 2800 MHz).

This module is configured to use two externally provided Local Oscillator (LO) inputs in order to provide a higher degree of flexibility and customized applications.

Digital control is provided through a Micro-D connector.

The unit is packaged in a rugged housing with hermetical seals and internal potting in order to provide higher reliability in difficult environments.

All specifications are customizable upon request. For more information, please contact:
sales@qmicrowave.com

Q Microwave 1591 Pioneer Way, El Cajon, CA 92020
Phone: 619-258-7322 E-mail: Sales@qmicrowave.com



Q MICROWAVE, INC.

0.5 to 18 GHz Wideband RF Downconverter With 1 GHz Instantaneous Bandwidth

Table 1: Electrical Specifications using Table of Applicable Test Conditions*

Parameter	Min.	Typ.	Max.	Units
RF Input Frequency Range	0.5		18	GHz
IF Output Center Frequency	1800	2300	2800	MHz
LO1 Input Frequency Range	5.0 *		16	GHz
LO2 Input Frequency Range	5.6 *		8.8	GHz
LO1 & LO2 Input Power	+10		+15	dBm
Instantaneous 3 dB bandwidth		1		GHz
Gain	-1	+3	+8	dB
Gain Flatness (0.5 to 18 GHz)		9		dB
Gain Variation over IF Passband (1000 MHz)		< +/- 2.25		dB
Noise Figure (NF)			10	dB
OIIP3	+30			dBm
Output 1 dB Compression Point (OP1dB)	+0			dBm
Spurious LO1 x LO2 (at -20 dBm Input)			-65	dBm
LO to Input Isolation (at -20 dBm Input)			-60	dBm
LO to Output Isolation (at -20 dBm Input)			-60	dBm
Switching Speed			1	usec
Max Power In			+1	dBm
Operating Voltage (+6 VDC)			560	mA
Operating Voltage (-6 VDC)			100	mA
VSWR IF Port			2.0:1 / 50% 2.5:1 / 100%	mA
VSWR RF Port			2.0:1 / 50% 2.5:1 / 100%	mA
Filter Specifications	Per Table 2			
Digital Switch Logic	Per Table 3			

*Note 1: Table of Final Test Sweeps & LO1/LO2 Inputs used to test the converter are on Website

Q Microwave 1591 Pioneer Way, El Cajon, CA 92020
Phone: 619-258-7322 E-mail: Sales@qmicrowave.com



Q MICROWAVE, INC.

0.5 to 18 GHz Wideband RF Downconverter With 1 GHz Instantaneous Bandwidth

RF Block Diagram

Q PN 102256 Wideband RF Downconverters have dual-stage downconverter approach as is depicted in the Block Diagram below. It will downconvert an RF Input signal to an IF Output signal, centered at 2314 MHz, with up to 1 GHz of Instantaneous Bandwidth.

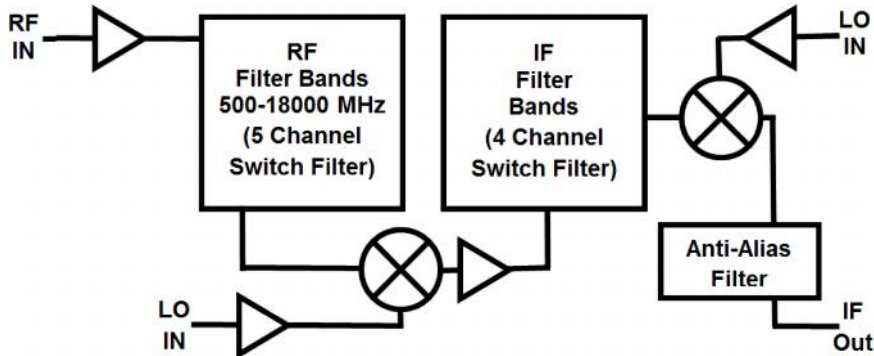

Mechanical Outline & Dimensions

1. **MATERIAL:**
 - A. HOUSING: ALUMINUM 6061-T6
 - B. COVER: ALUMINUM 4032 OR 4047
2. **SEAL METHOD:** LASER WELD
(VACUUM BAKE 2 HRS. MIN @ 125°C ± 5°C BEFORE SEALING)
3. **HERMETICITY:**
 - A. GROSS - LEAK LEVEL PER MIL-STD-202, M112, COND. D
4. **FINISH:**
 - A. LID SURFACE AND WELD ZONE: CHEMICAL CONVERSION COAT PER MIL-DTL-5541, CLASS 1A
 - B. DC CONNECTOR SHELL: CHEMICAL CONVERSION COATED PER MIL-C-5541, CLASS 1A
 - C. THREADED HOLES: UNPLATED (BARE ALUMINUM)
 - D. SMA CONNECTORS: PASSIVATED STAINLESS STEEL
 - E. ALL OTHER SURFACES: HIGH PHOSPHORUS NICKEL PLATED PER ASTM B733, TYPE V (10% - 13%), .001-.0015 IN THICK

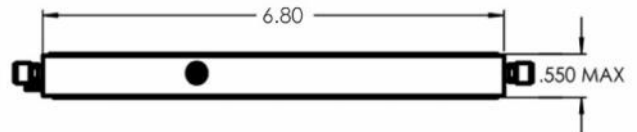
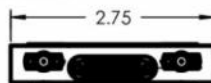
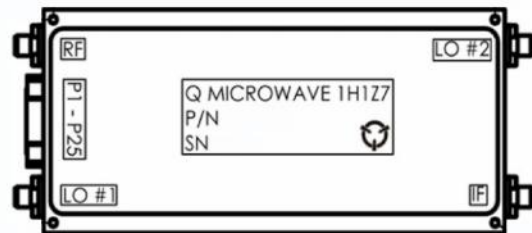

5. **INPUTS/OUTPUTS:**
 - A. RF CONNECTORS - SMA, FIELD REPLACEABLE
 - B. DC CONNECTOR: 25 PIN MICRO-D
6. **MARKING:** LABEL AS SHOWN
7. **NOTES:**
 - A. WEIGHT: 14 oz. MAX
 - B. ESD HANDLING PRECAUTIONS TO BE OBSERVED
 - C. ALL DIMENSIONS ARE PRIOR TO PLATING

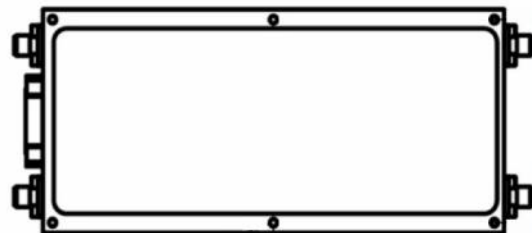

Q Microwave 1591 Pioneer Way, El Cajon, CA 92020
Phone: 619-258-7322 E-mail: Sales@qmicrowave.com



Q MICROWAVE, INC.

0.5 to 18 GHz Wideband RF Downconverter With 1 GHz Instantaneous Bandwidth

Table 2: Filter Specifications

Band	Fc (MHz)	1.5 dB BW (MHz)	Lower Rejection		Upper Rejection	
			dB	MHz	dB	MHz
RF1	1550	500 - 2600	50	20 - 400	50	2990 - 11000
					40	11000 - 18000
RF2	3740	2380 - 5100	50	20 - 2050	50	5840 - 11000
					40	11000 - 18000
RF3	6490	4880 - 8100	50	20 - 4250	50	9260 - 18000
RF4	9990	7880 - 12100	50	20 - 6750	50	13820 - 18000
RF5	14940	11880 - 18000	50	20 - 10350	40	at 24000
IF1	4000	3500 - 4500	50	20 - 3000	50	5160 - 13000
IF2	5000	4500 - 5500	50	20 - 3900	50	6300 - 13000
IF3	6600	6100 - 7100	50	20 - 5300	50	8125 - 13000
IF4	7350	6850 - 7850	50	20 - 6000	50	8980 - 13000
Anti-Alias	2300	1800 - 280	50	20 - 1500	50	3300 - 15000

Table 3 Digital Switch Logic

B0R	B1R	B2R	B0I	B1I	Filter	Filter
1	0	0	0	0	RF1	IF1
1	0	0	1	0	RF1	IF2
1	0	0	0	1	RF1	IF3
1	0	0	1	1	RF1	IF4
0	1	0	0	0	RF2	IF1
0	1	0	1	0	RF2	IF2
0	1	0	0	1	RF2	IF3
0	1	0	1	1	RF2	IF4
1	1	0	0	0	RF3	IF1
1	1	0	1	0	RF3	IF2
1	1	0	0	1	RF3	IF3
1	1	0	1	1	RF3	IF4
0	0	1	0	0	RF4	IF1
0	0	1	1	0	RF4	IF2
0	0	1	0	1	RF4	IF3
0	0	1	1	1	RF4	IF4
1	0	1	0	0	RF5	IF1
1	0	1	1	0	RF5	IF2
1	0	1	0	1	RF5	IF3
1	0	1	1	1	RF5	IF4
All Other States					OFF	OFF

Q Microwave 1591 Pioneer Way, El Cajon, CA 92020
Phone: 619-258-7322 E-mail: Sales@qmicrowave.com